

LOTAR 101

Jeff Klein - The Boeing Company
Bernd Feldvoss - Airbus Commercial Aircraft

GLOBAL PRODUCT DATA INTEROPERABILITY SUMMIT 2023



BOEING is a trademark of Boeing Management Company Copyright © 2023 Boeing. All Rights Reserved
Copyright © 2023 Elysium Inc. All Rights Reserved
Copyright © 2023 Northrop Grumman Corporation. All Rights Reserved
Copyright © 2023 Parker-Hannifin Corporation. All Rights Reserved
Copyright © 2023 PDES. All Rights Reserved

Presenters Bio

Global Product Data Interoperability Summit | 2023

Bernd Feldvoss is PLM Interoperability Standards Specialist at Airbus in Hamburg, Germany. Bernd joined Airbus in 1998 and worked as a Systems Engineer where he was involved in the development of Data Exchange Methods. During this time he participated in international working groups and made a contribution to the “Airbus Concurrent Engineering (ACE)” project. He was involved in projects including the launching of the A380 and establishing cDMU between the UK, Spain, France, and Germany. Additionally, In 2006, Bernd was appointed as the Team leader for Product Data Exchange at Airbus Germany where he managed 15 internal and external employees. He was appointed to his current role in 2022. As part of his professional life, Bernd represents Airbus on numerous committees including; the prostep ivip Technical Steering Committee and the JT Open Technical Review Board. He is also a member of the Global Collaboration Working Group in the CIMdata managed PLM Aerospace & Defense Action Group. Bernd studied Computer Science at the University of Hamburg, where his focus was on Computer Aided Engineering.



[LinkedIn](#)

Email:

Bernd.Feldvoss@airbus.com

Presenters Bio

Global Product Data Interoperability Summit | 2023

Jeff Klein is a current co-leader of the Long Term Archiving and Retrieval (LOTAR) consortium for the development of the EN/NAS 9300 series of process standards, which are for the long term archiving and retrieval of digital design data. In addition, he co-leads the Basic and Common WG and participates on the PDM Implementor Forum User Group. Prior to these roles he was a participant and former leader of the PDM WG within LOTAR. Prior to the formation of LOTAR, he was a participant on an AIA committee, which published SAE ARP 9034, A Process Standard for the Storage, Retrieval and Use of Three-Dimensional Type Design Data.

He began his career at Boeing in 1989 as an electrical engineer on the 747/767 programs. He has worked on the development of the 777 program, in Electrical Systems, in Systems Engineering, and in Engineering Operations. His work on implementation of loadable software led to roles in configuration management and industry standards development.

He is now the lead of a core engineering group which supports all aspects of Configuration Management for commercial and derivative programs from Systems to Structures, and all points in the product lifecycle, from development to production certification to in service support. He has been involved in the implementation of multiple product lifecycle management systems and associated process and data standards. He has supported and led activities to flow down and verify implementation of CM process and tool requirements to design and build suppliers. He has coordinated with the FAA on Boeing's implementation of CM.

In addition to LOTAR, he is a voting member on the SAE G-33 Committee, Configuration Management, and has contributed to the development of SAE EIA 649 and related standards for implementation of Configuration Management (CM). He is the SME for internal Boeing procedures which implement EIA-649 principles across the Boeing enterprise.



Email:
jeff.r.klein@boeing.com

LOTAR Project “On A Page” www.lotar-international.org

Global Product Data Interoperability Summit | 2023

- LOTAR is an international consortium of Aerospace manufacturers
- Prime objective is creation and deployment of the EN/NAS 9300 series of standards for long-term archiving and retrieval of digital data, based on standardized approaches and solutions.
- Integration of LOTAR requirements in software tools ensured by close cooperation with:

MBx Implementor Forum (MBx-IF):

- Facilitated by AFNeT, PDES, Inc., and prostep ivip
- Consists STEP Translator & Validation Tool vendors for of CAD, CAE, EWIS and PDM
- Supports AP203, AP209, AP214, AP239, AP242, AP243
Supports AP242 Business Object Model XML

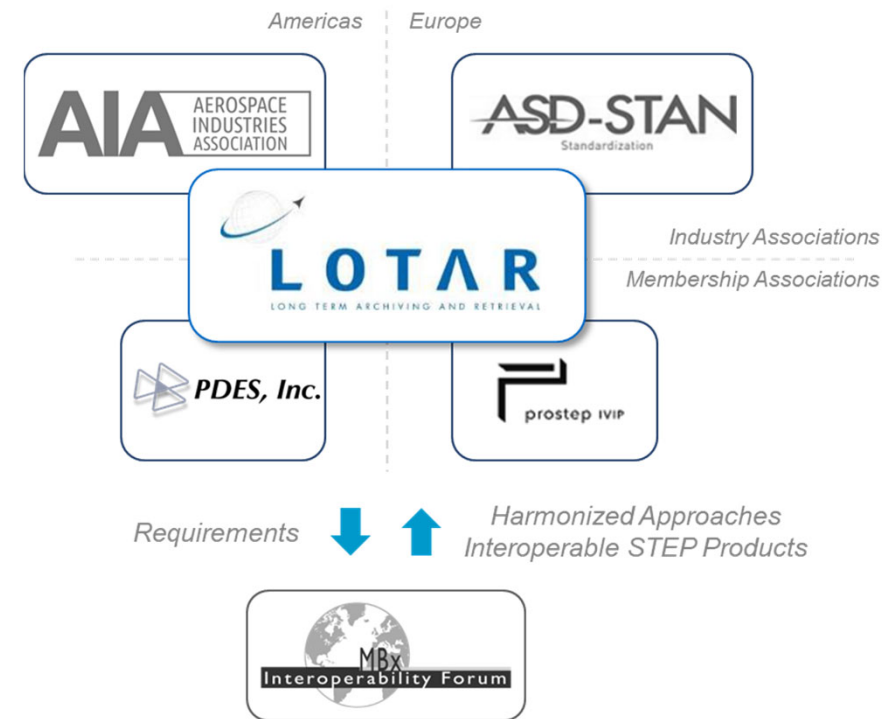



LOTAR DRIVERS

Information Lifecycle Planning

Global Product Data Interoperability Summit | 2023

Driving Questions

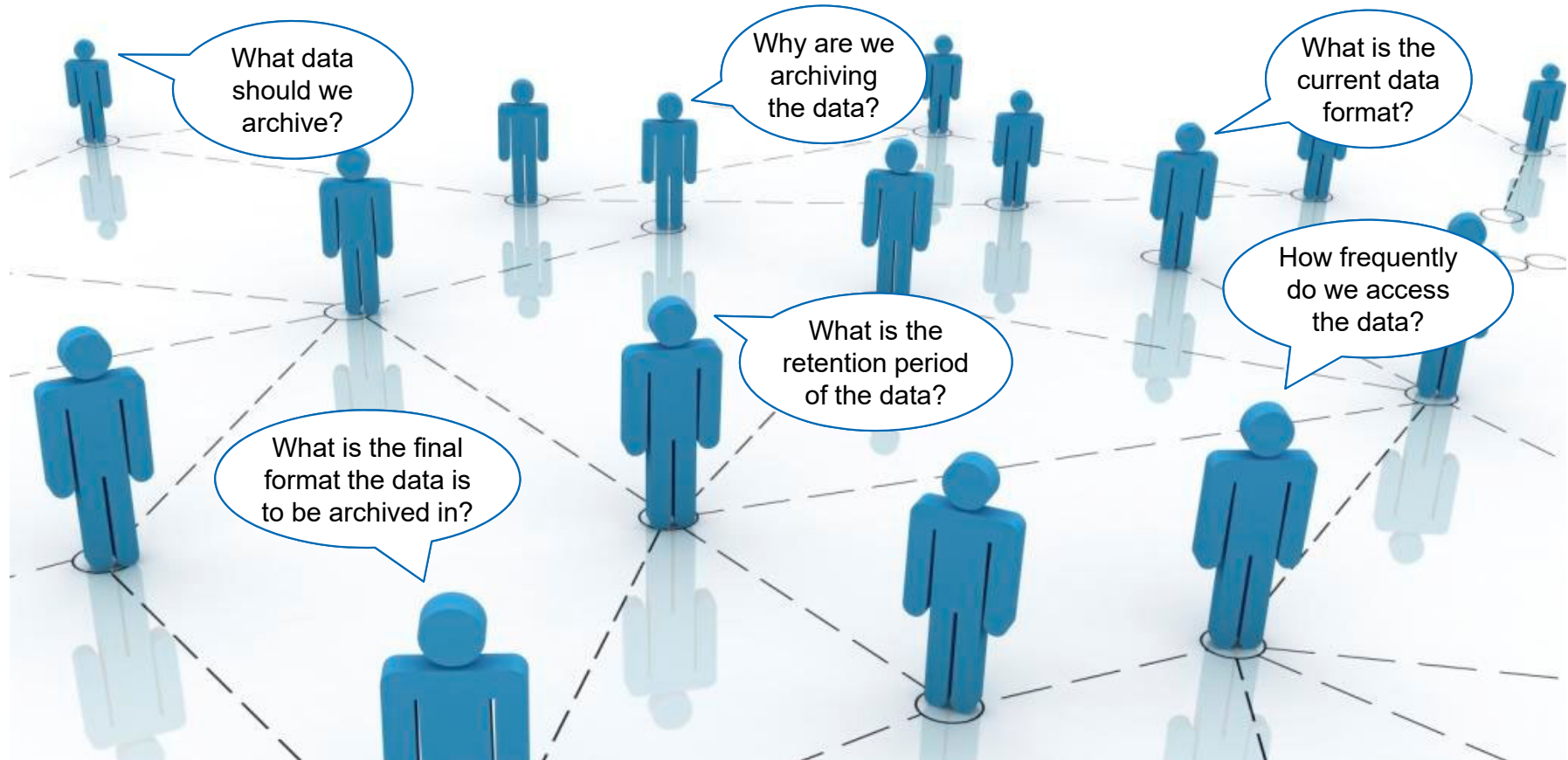

LOTAR Problem Statement

Global Product Data Interoperability Summit | 2023

With the emergence of digital data-based processes, including model-based definition, requirements were identified which predicate the need for a long-term data retention solution(s) to meet the regulatory and business requirements. Traditional legacy retention and retrieval methods do not support complex digital product definition data.

Past

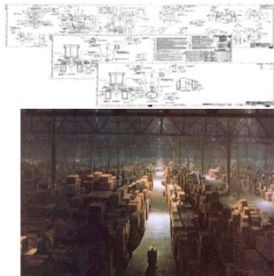

Paper-based process

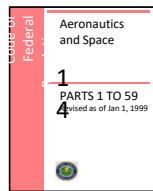

Code of Federal Regulations

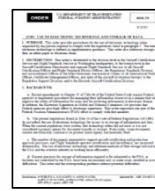

FAA Order 8000.79

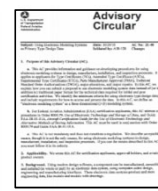

AC21-48

Requirements

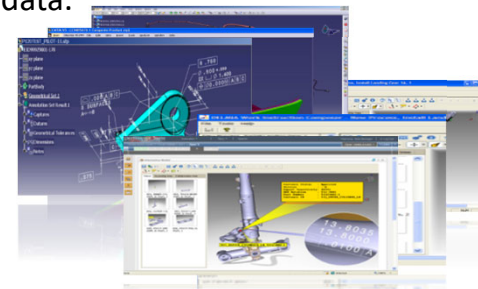

Digital-based process

Future

Project Description

The project goal is to *develop, publish and maintain standards* designed to provide the capability to *archive and retrieve* digital product and technical information, including 3D CAD and PDM data, in a *standard neutral form* that can be read and reused throughout the product lifecycle.

The standards are published as NAS 9300 US (EN 9300 Europe), series and cover both the information content as well as the processes required to ingest, store, administer, manage and access the information.

Key Team Members:

Team Leads and Represented Companies:

- **Boeing:** J. Klein, J.C. Mendo, S. Galt, A. Bingcang, J. VanHorne
- **Lockheed Martin:** J. Holmlund, M. Jahadi, C. Simpson
- **GE:** Xuefeng Zhang
- **Gulfstream:** D. Ganser, L. Nash
- **Raytheon:** J. Ganguli, I. Parent
- **Airbus:** B. Feldvoss, P. Duchier, F. Darre, K. Hall



The LOTAR project: Supporting the longevity of Aerospace & Defense 3D Model based definitions

Global Product Data Interoperability Summit | 2023

- CAD S/W versions change **every 6 to 12 months**, CAD generations change **every 10 years**.
- Aircraft lifecycle of **70+ years**
- The Lifecycle of software & hardware is short compared to the lifecycle of an aircraft or a defense system (nuclear missile...)

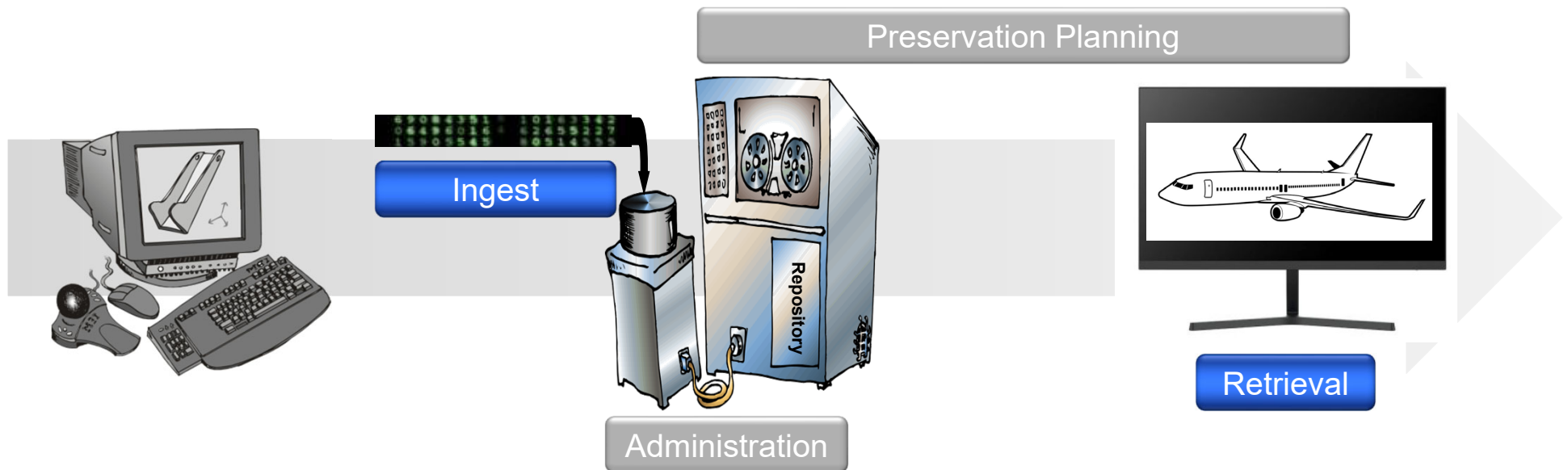

Technical and IT Background

Global Product Data Interoperability Summit | 2023

- The life cycle of applications and storage technologies has to be considered by setting up a long-term archiving and retrieval standard:

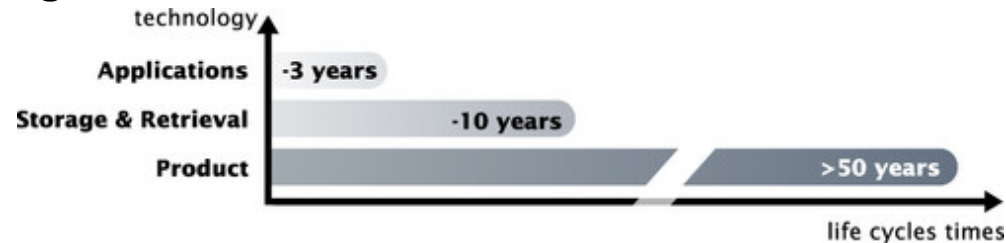

- Continuous development of technical product documentation technology leads to changes in methods and tools, which are used for design, manufacturing, customer support and archiving.
 - New releases of CAD / CAM / CAE / PDM / ... systems offering new functionalities
 - After each migration, the data shall be checked for consistency and completeness.
→ A conversion of the native product data into a more stable format mitigates the risk of information loss and minimizes the cost of migration.

Motivation for LOTAR

Global Product Data Interoperability Summit | 2023

- Meeting the legal and business requirements of the aerospace and defense industry:



- EN/NAS 9300 considers requirements from multiple sources:
 - Legal and certification rules
 - Regulations on long term archiving of technical documentation
 - Design reuse
 - Support in operation
- In addition to legal requirements, there are industry established standards, company specific rules and recommendations.
- The EN/NAS 9300 standards define architecture, process and data formats to fulfill these requirements.

Regulatory requirements for LOTAR

Global Product Data Interoperability Summit | 2023

Document & Data Archiving is a legal obligation defined by external requirements such as the FAA and by internal company policies.

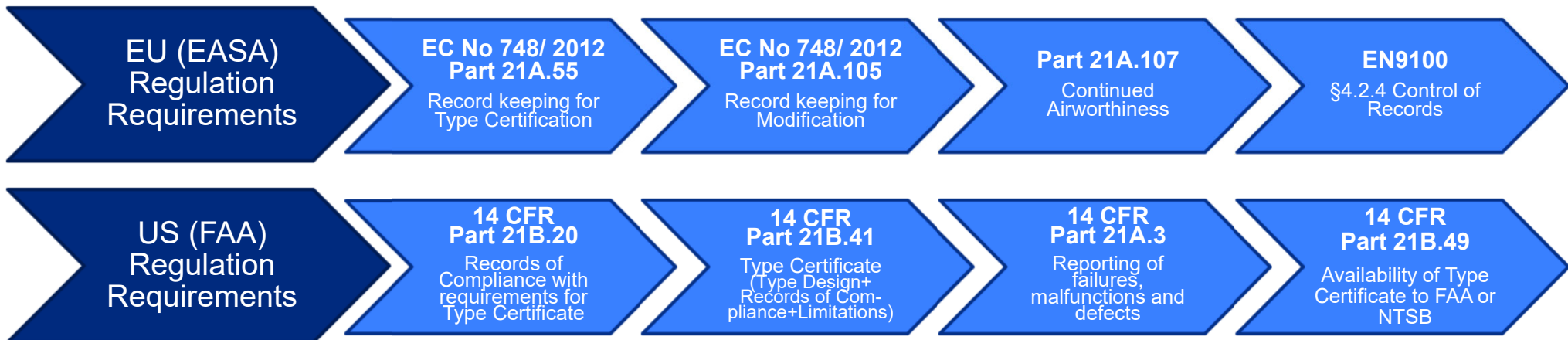

The FAA and EASA have promoted efforts to harmonize the regulations, so there are many similarities between them.

Objectives & Benefits of LOTAR

Global Product Data Interoperability Summit | 2023

- **Objectives include:**
 - Developing standards for archiving and retrieval of product data
 - Providing methods, process modules and data model(s), to enable long term archiving of CAD, PDM and additional technical data e.g., MBSE, requirements, electronics & software etc.
 - Developing recommendations for practical introduction of long-term archiving of product data for example for 3D CAD and PDM data, in the industry
- **Benefits include:**
 - Process security achieved through implementation of archival systems compliant to internationally accepted standards
 - Aerospace and Defense authorities accept standards due to intense collaboration during standards creation
 - Applicable archiving workflow supported by interfaces & functionalities based on open standards
 - By solving the challenges of long-term data retention, issues of data exchange are addressed

Development and use of LOTAR standards by the A&D industries allow for decreasing the costs and risks of long term archiving of aerospace product data

ORGANIZATION

Who does LOTAR work with?

LOTAR Organization

Global Product Data Interoperability Summit | 2023

External View

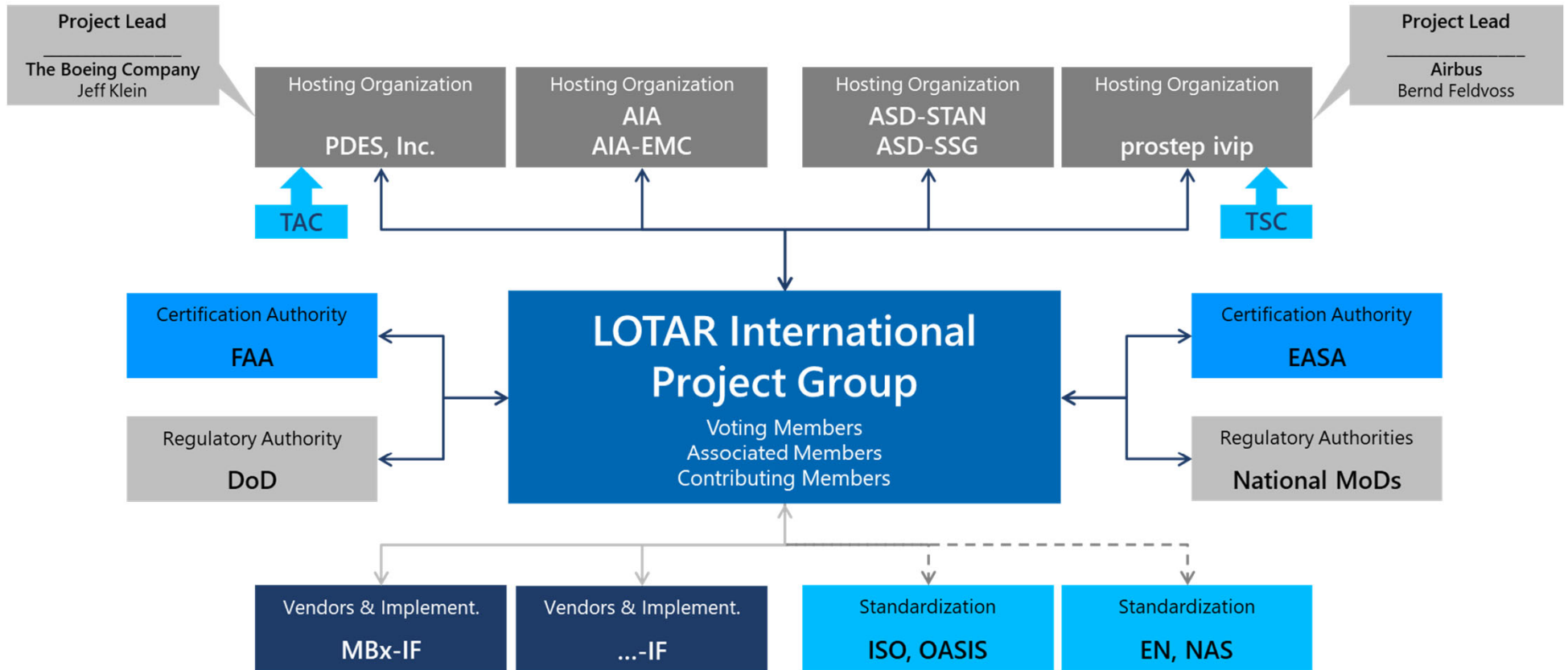

LOTAR Organization

Global Product Data Interoperability Summit | 2023

Internal View

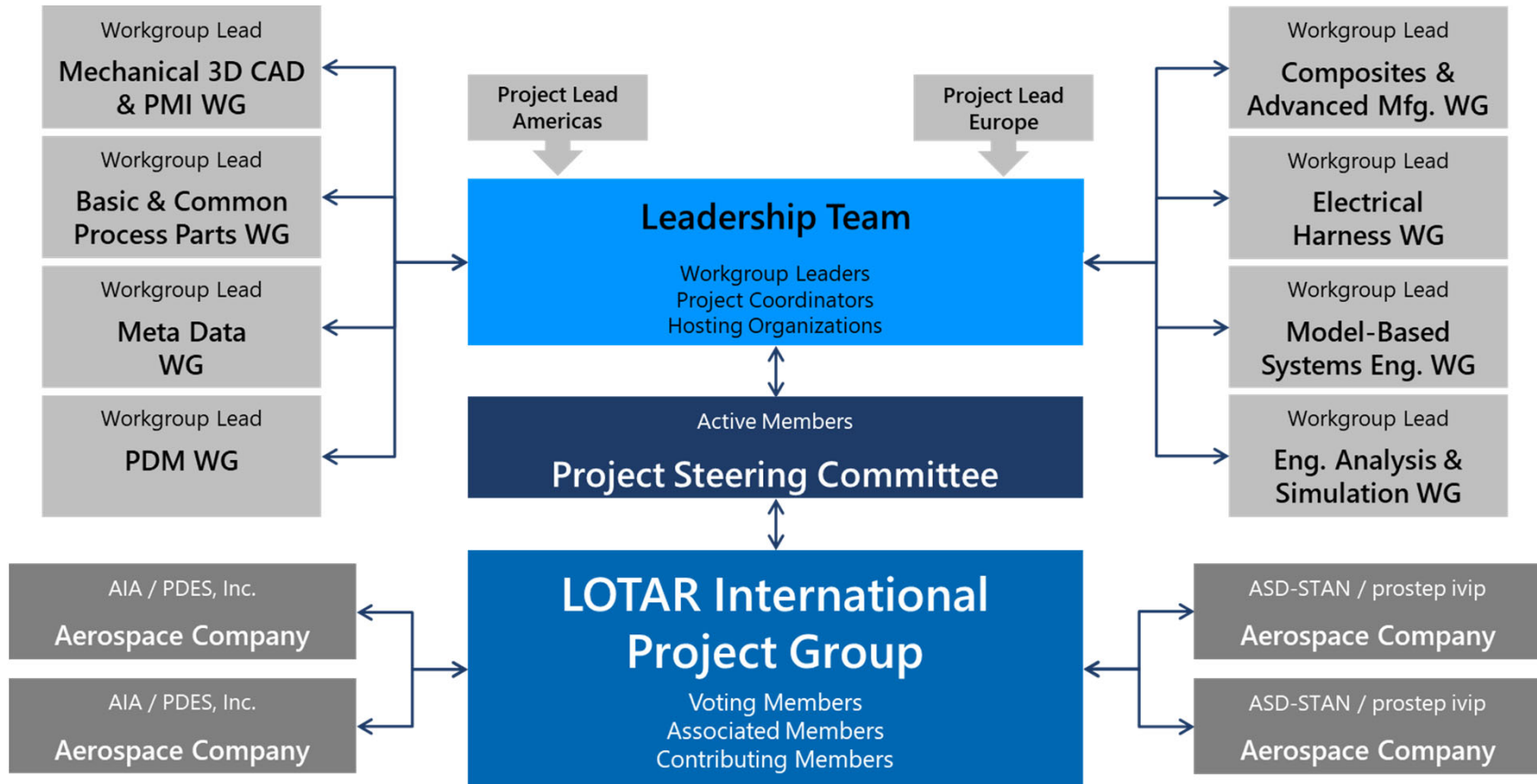

Industry Members

Global Product Data Interoperability Summit | 2023

- **Airbus Group**
 - **Airbus Commercial Aircraft**
 - **Airbus Defence & Space**
 - **Airbus Helicopters**
- **The Boeing Company**
- **Embraer**
- **General Electric**
- **Gulfstream**
- **Leonardo**
- **Lockheed Martin**
- **Raytheon Technologies**
 - **Pratt & Whitney**

OAIS

LOTAR Baseline

LOTAR Standard Foundation ISO 14721:2012 (OAIS)

Global Product Data Interoperability Summit | 2023

- “Open Archive Information System” (OAIS) Reference Model is basis for LOTAR processes
- Developed by Aerospace and Defense Industry
- Extended to meet the specific requirements of LOTAR

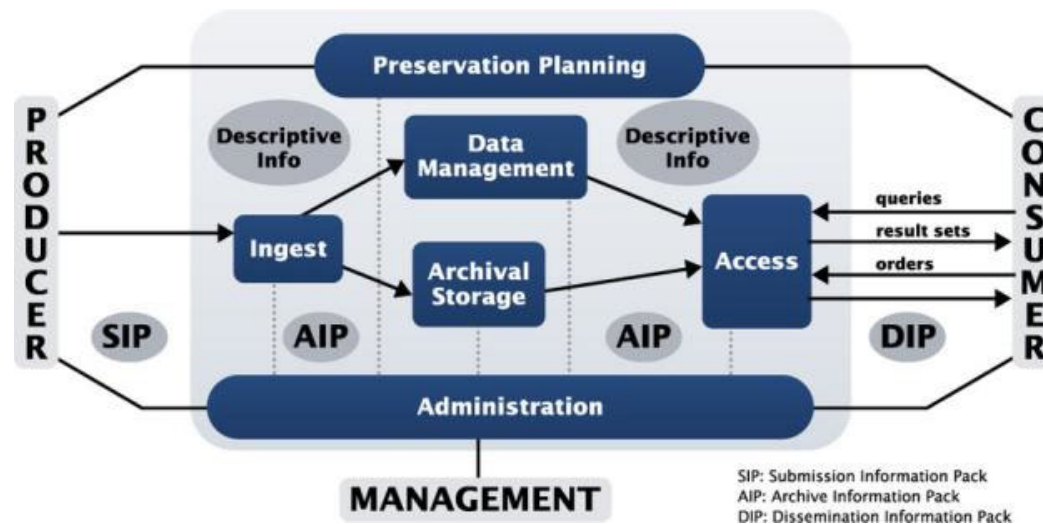

- As neutral data format for the archives has been chosen (STEP and other standards)

LOTAR V MODEL

Standards Development V Model

Global Product Data Interoperability Summit | 2023

LOTAR to IF to PDES (STEP)

- **The consortium of organizations involved with LOTAR take a systems engineering approach to validate requirements and verify they can be implemented.**
 - The LOTAR (EN/NAS 9300) process standards are based on the Open Archive Information System standard (ISO 14721).
 - The Implementor Forums, consisting of User Groups (e.g. Boeing, Airbus, Gulfstream, Raytheon, ..., as well as automotive OEMs) and Implementer Groups (e.g. Dassault Systems, prostep, ...) develop recommended practices based on LOTAR (and other) use cases; using ISO 10303 as an exchange format.
 - The ISO 10303 (STEP) and other data standards are used to verify the ability to implement LOTAR use cases, and in turn are refined and developed to address identified gaps.

“V cycle” for development and validation of LOTAR standards

Global Product Data Interoperability Summit | 2023

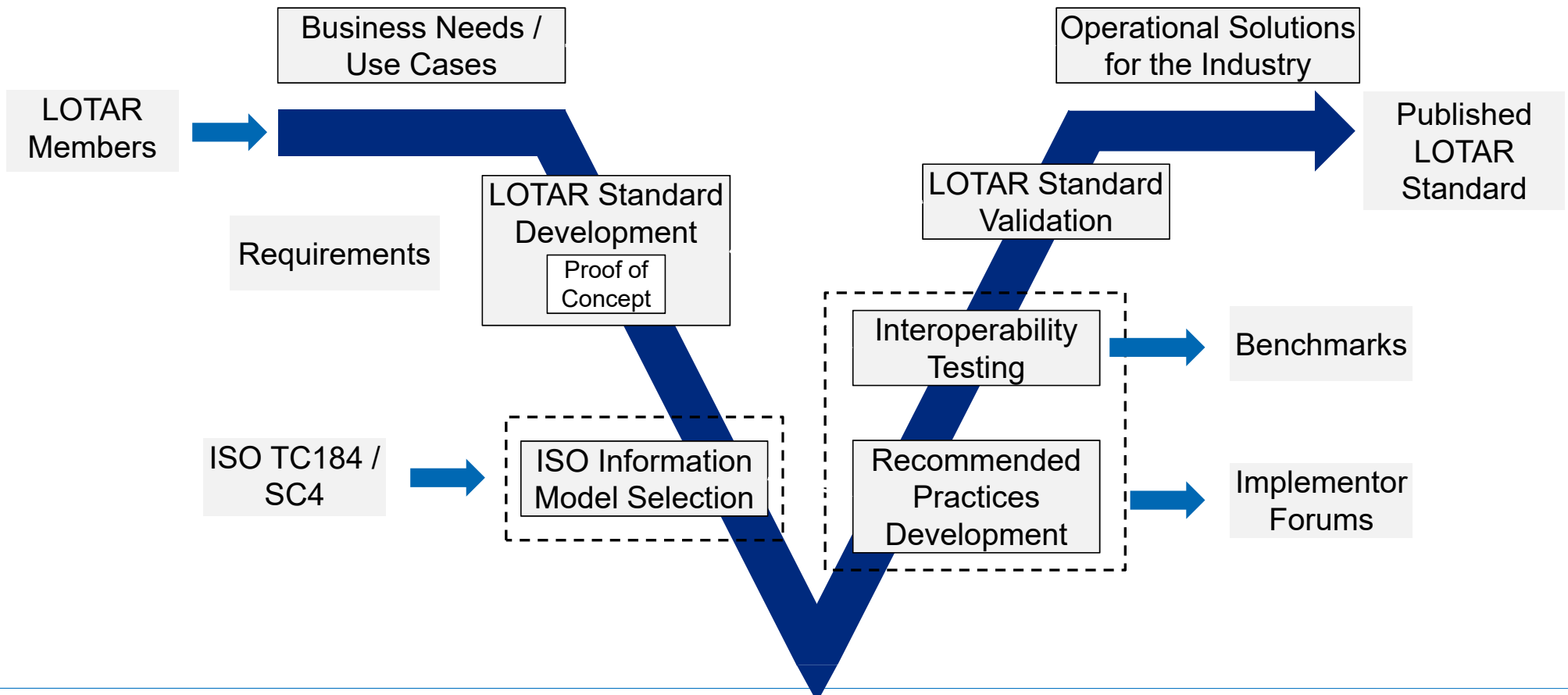



LOTAR WORKING GROUPS

LOTAR Working Groups

Global Product Data Interoperability Summit | 2023

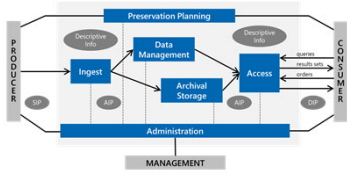

2018 →

Basic & Common Process Parts

EN/NAS 9300-00x & -01x series

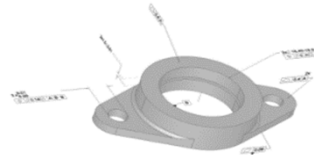

2004 →

Mechanical 3D CAD with Product and Manufacturing Information (PMI)

EN/NAS 9300-1xx series

STEP AP203 Ed.2, AP214 Ed.3, AP242

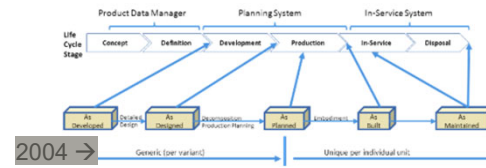

2004 →

Product Data Management (PDM)

EN/NAS 9300-2xx series

STEP AP239, AP242

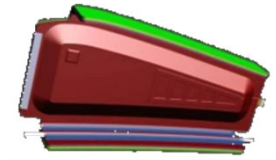

2009 →

Composites and Advanced Manufacturing

EN/NAS 9300-3xx series

STEP AP203 Ed.2, AP242

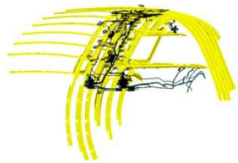

2012 →

Electrical Wiring Harness

EN/NAS 9300-4xx series

STEP AP242 Ed.2

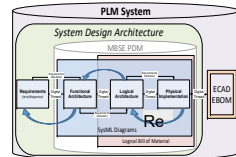

2018 →

Model-Based Systems Engineering (MBSE)

EN/NAS 9300-5xx series

STEP AP233, AP239, AP242, AP243
FMI, SysML, AADL, ReqIF...

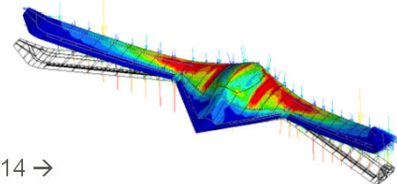

2014 →

Engineering Analysis and Simulation (EAS) *(on hold)*

EN/NAS 9300-6xx series

STEP AP209 Ed.2

LOTAR EN/NAS 9300 STANDARDS

LOTAR Deliverables

LOTAR Standards Overview

Global Product Data Interoperability Summit | 2023

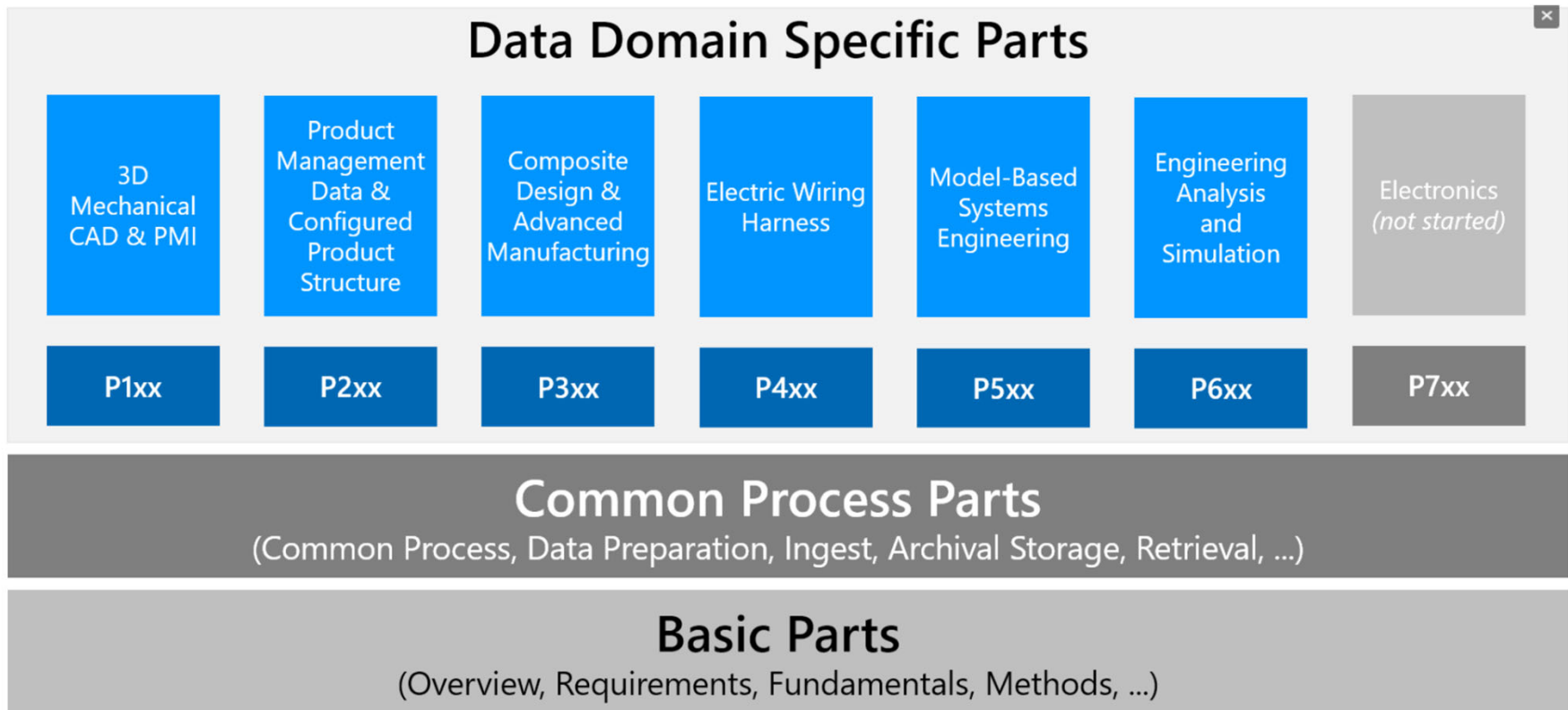

Recent Highlights per Domain

Global Product Data Interoperability Summit | 2023

Basic & Common Process Parts [00x] [01x]

- Completed update LOTAR Part 001
- Part 003 update is ready for internal ballot.
- Parts 002, 005, 007, 010, and 021 are in work.

Mechanical 3D CAD with PMI [1xx]

- Part 100 updated. In external ballot.
- Part 120, 125 preparing for EN publication.
- Launch of two pilot projects for assembly PMI

Product Data Management (PDM) [2xx]

- Part 210 (“as designed”) final editing
- Part 230 (“as built”) in work
- Developed use case for “Alternate/Substitute Parts” for PDM-IF

Composites and Advanced Manufacturing [3xx]

- Defined new requirements (e.g., Rosette guide by curve 90°, Splice Zone, No Drop Off Zone, Additional Geom., etc.)
- Targeted for AP242 Ed 4

Electrical Wiring Harness [4xx]

- Reviewed and expanded essential information in Part 410
- Launched pilot project based on AP242 Ed.3, coord. with EWIS-IF
- Support development of rules for automated checking of AP242XML files for quality control

Model-Bases Systems Engineering (MBSE) [5xx]

- Working on Part 500 (LTA of MBSE data) and 520 (How to archive simulation models)
- Planning prototype and use case on linking
- Modelica paper on 2022 prototype

Engineering Analysis and Simulation (EAS) [6xx]

- Drafts available of Parts 600 (General concepts) and 620 (Structural analysis)
- WG currently on hold



BASIC & COMMON WG

Fundamental and Conceptual Process Methodologies

Basic and Common WG

Global Product Data Interoperability Summit | 2023

Basic Parts and Common Process Parts

- **Basic Parts**
 - Fundamental process requirements standards based on OAIS
- **Common Process**
 - Process standards derived from the basic parts, common to all domains
- **Goals and Objectives**
 - The specific goal of the Basic and Common Parts Working Group is focused on the fundamental and conceptual process methodologies of long-term preservation of digital product and technical data.

3D MECHANICAL CAD & PMI WG

3D CAD with Product and Manufacturing Information (PMI) –
Mechanical, PMI, Manufacturing Features

LOTAR WG: 3D Mechanical CAD with PMI (EN/NAS 9300-1xx)

Global Product Data Interoperability Summit | 2023

- **Scope:**

- The specific goal of the Mechanical 3D CAD with Product and Manufacturing Information (PMI) workgroup is focused on the preservation of the explicit 3D Geometric shape representation and associated Product and Manufacturing Information. The results are documented as NAS/EN 9300-1xx parts. Deliverables*):

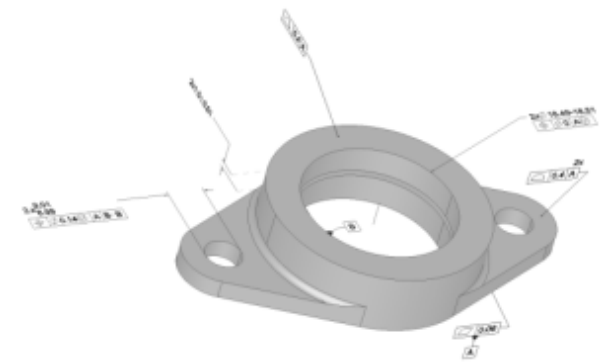

- **Parts:**

- 100 (Common Concepts)
- 110 (Explicit 3D Geometry)
- 115 (CAD Assembly Structure)
- 120 (PMI Graphic Presentation)
- 121 (PMI Semantic Representation)
- 125 (Assembly PMI Graphic Presentation)
- 126 (Assembly PMI Semantic Representation)
- 132 (Representation and Presentation of Holes and Fasteners)
- Comprehensive suite of test models
- Numerous pilot projects in cooperation with the MBx-IF
- Support of STEP AP242 development and associated Recommended Practices

(*): Accomplished or in work; more planned

Validation of LOTAR STEP Data

Global Product Data Interoperability Summit | 2023

- A distinctive feature of the combined use of LOTAR and STEP is the use of Validation Properties
- Validation Properties are key characteristics of a digital model that help to ensure consistency of the data

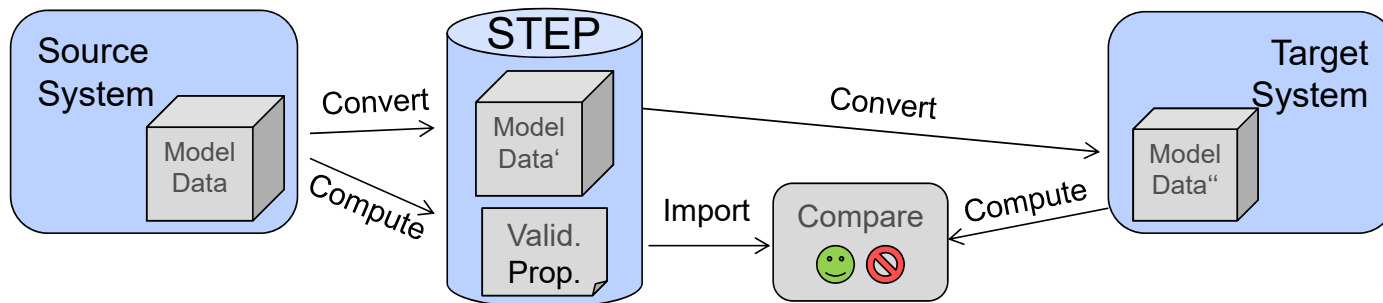

- They are computed by the exporting system using geometric elements in the STEP file
- Any importing system will compare its import results with these properties and thus determine success of the data transfer.

PDM WG

Product Data Management (PDM) / Product Lifecycle
Management – Product Structure: As-Designed, As-Built and As-
Maintained

LOTAR WG: PDM (EN/NAS 9300-2xx)

Global Product Data Interoperability Summit | 2023

- **Scope:**

- Archive and retrieve Product Data Management information in a standard neutral form that can be read and reused throughout the product lifecycle
- Preservation of digital PDM information along the product lifecycle: in development, as designed, as planned, as delivered and as maintained.

- **Deliverables^(*):**

- Part 200 Fundamentals and Concepts
- Part 205 Product Structure Validation Properties
- Part 210 as designed (ed. 2 incl. effectivities)
- Part 220 as planned (cancelled, records covered in 230)
- Part 230 as built (dependency on Part 210)
- Part 240 Product Development (including prelim design review, critical design review, FAI, etc.),
- Part 250 Change Management



(*): Accomplished or in work; more planned

Validation of LOTAR STEP Data

Global Product Data Interoperability Summit | 2023

- An example application of a validation property is the LOTAR technical specification EN/NAS 9300-205 on “Product Structure Validation” using hash code to check consistency of data between systems

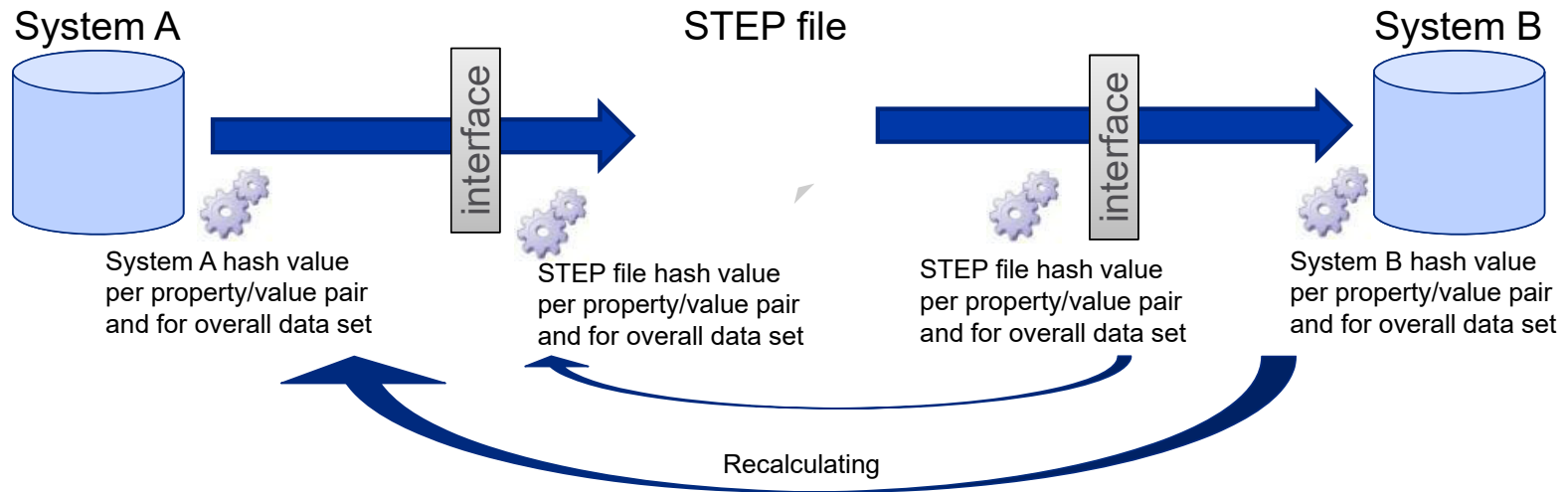

COMPOSITES (DESIGN FOR ADVANCED MANUFACTURING) WG

Representing design requirements for advanced manufacturing
(composite, additive, etc.)

LOTAR WG: Advanced Manufacturing (EN/NAS 9300-3xx)

Global Product Data Interoperability Summit | 2023

- **Scope:**

- Preservation of new information required in STEP data model for Composite design and Additive manufacturing:
- Organic Shapes and Surface Models
- Design Tools
- Representation Formats
- Preservation of CAD 3D tessellated solids
- 3D composite structures information such as Sequences, Plies, Cores, Material properties, Rosette, Orientation...
- Preservation of CAD 3D tessellated solids

- **Deliverables^(*):**

- Parts 300 (Common Concepts), 310 Ed.1 (“exact implicit”–Ply Definition), 310 Ed.2 (“approximate explicit”–3D Tess. Solid)
- Support of STEP AP242 Development and associated Recommended Practices
- Prototype part developed to anticipate future structures to demonstrate concepts
- Independent tests of CAD tools for the purpose of interoperability

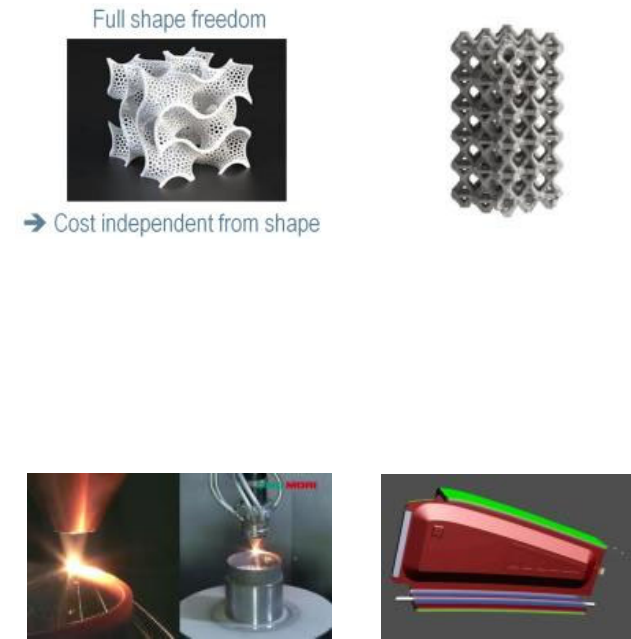

(*): Accomplished or in work; more planned

ELECTRICAL HARNESS WG

Digital electrical harness models for
design, manufacturing, and support.

LOTAR WG: Electric Harness (EN/NAS 9300-4xx)

Global Product Data Interoperability Summit | 2023

- **Scope:**
 - **Preservation of digital electrical harness models for**
 - Design
 - Certification
 - Manufacturing
 - Support
- **Deliverables^(*):**
 - **Part 400 (Common Concepts),**
 - **Part 410 (Physical harness definition for design & construction)**
 - **Preparation of test cases for physical electrical harness definition**
 - **Data model for Electrical Harness Data is fully defined in AP242 ED3**
 - **Coordination with other standardization projects related to electrical harness (STEP AP 210, AP239, VDA VEC specification, ...)**

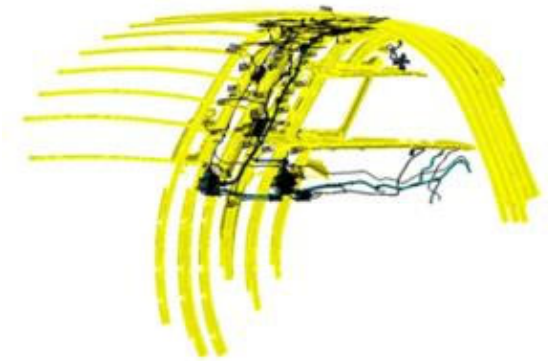

(*): Accomplished or in work; more planned

MODEL BASED SYSTEMS ENGINEERING WG

Preservation of system-descriptive and analytical models that are explicit, coherent, and consistent.

LOTAR WG: Model-Based System Eng. (EN/NAS 9300-5xx)

Global Product Data Interoperability Summit | 2023

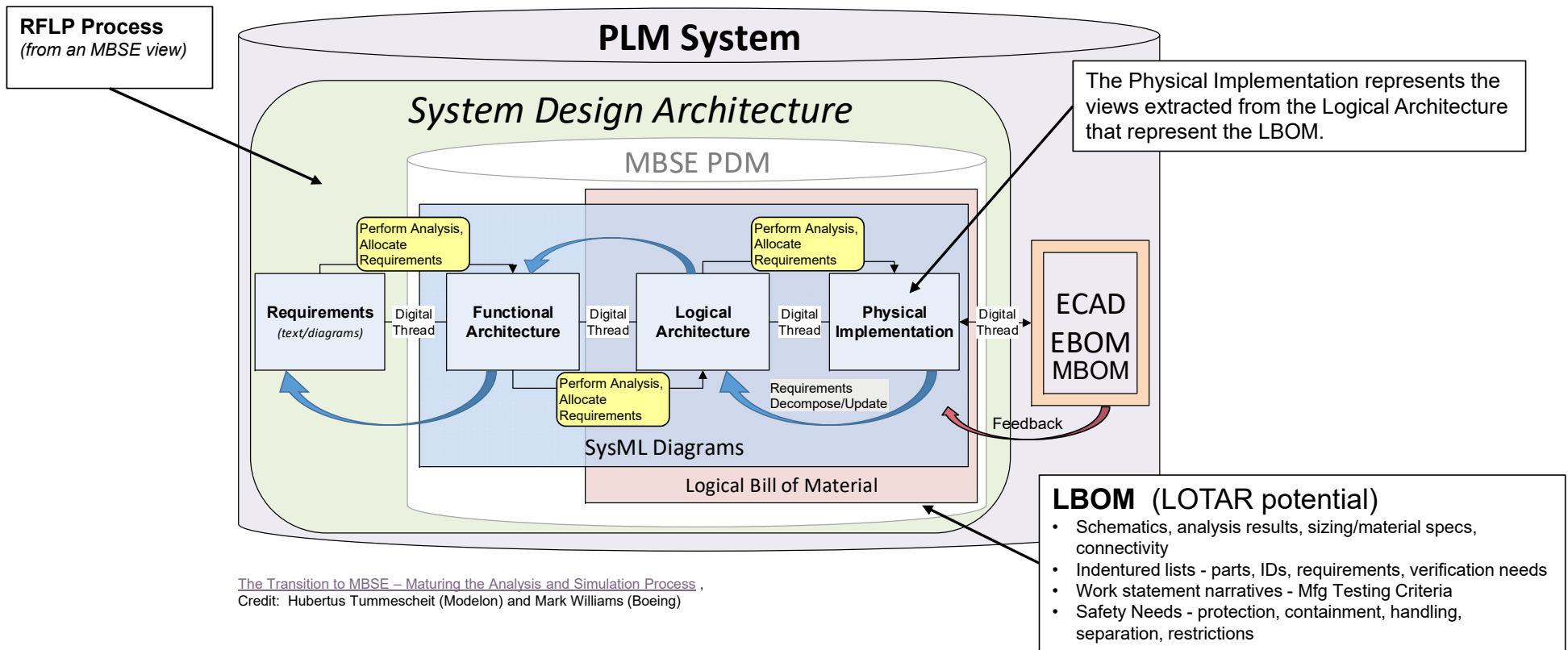

ENGINEERING ANALYSIS AND SIMULATION WG

Analysis and Simulation models, e.g. Finite Element Analysis

LOTAR WG: Engineering Analysis & Simulation (EN/NAS 9300-6xx)

Global Product Data Interoperability Summit | 2023

RESTART

- **Start of the LOTAR working group for “Engineering Analysis and Simulation” in 2014**

- **Scope: Preservation of Simulation and Analysis information**

- **Deliverables(*):**

- Part 600 (Fund. & Concepts),
- Part 610 (Simulation Data Management)
- Part 620 (Structural Analysis information)

- **Coordination with other standardization projects related to S & A (**

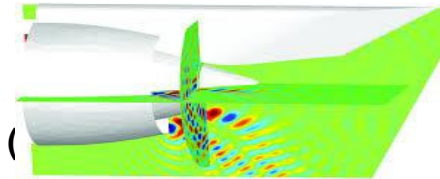

www.ap209.org/

- **Scope of ISO STEP AP 209e2 “Multi-Disciplinary Analysis and Design”**

- **Structural analysis**
- **Computational Fluid Dynamic**

- **Launch of a “CAE IF” as part of the CAx Implementor Forum planned for summer 201**

- **Regular coordination with NAFEMS (USA, Europe)**



(*): Accomplished or in work; more planned

STEP AP209 edition 2: Multidisciplinary analysis and design

Global Product Data Interoperability Summit | 2023

RESTART

- **ISO 10303 STEP AP209 ed2** is the target data model for simulation data long term archiving (LOTAR)
- STEP AP209 public web site: www.ap209.org
- Governance by ISO Technical Committee 184 for Industrial Automation Systems and Integration, Subcommittee 4 for Industrial Data

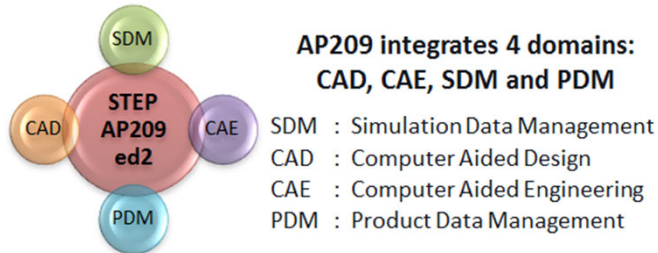

Development History

- AP209 ed1 published in 2001
- AP209 ed2 became an [ISO International Standard](#) Dec. 1st 2014
- Builds upon the full capabilities of [STEP AP242 ed1](#) (*Managed Model Based 3D Engineering*)
- Edition 2 scope now includes:
 - *Product definition (product structure and 3D shapes)*
 - *Configuration control information*
 - *Finite element data (linear statics and modes)*
 - *Material specifications & properties*
 - *Computational Fluid Dynamics (based on CGNS Std.)*
 - *Generic structured and unstructured analysis mesh*
 - *Meshless numerical analysis*
 - *Discrete/continuous field representation*
 - *Kinematics analysis*

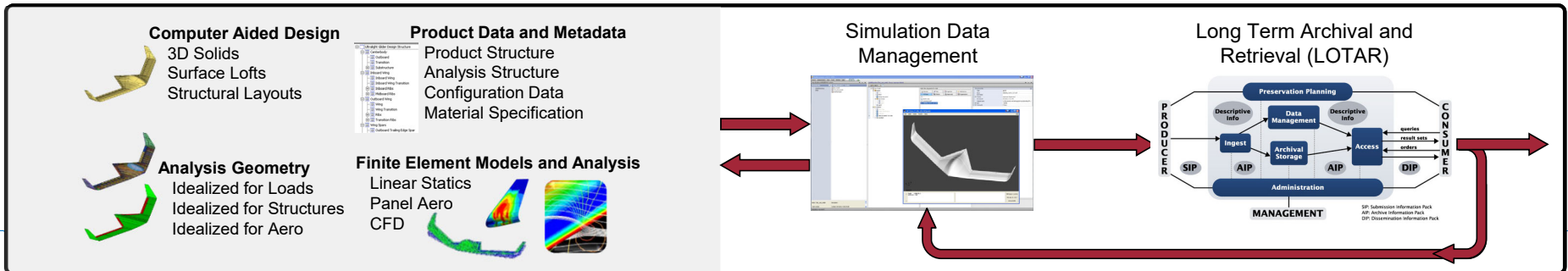

SUMMIT 2023

IMPLEMENTOR FORUMS

What is the MBx-IF?

Global Product Data Interoperability Summit | 2023

- **The Interoperability Forums bring together users and vendors from different domains to discuss common issues and approaches at the data and application level**
- **The MBx-IF is an umbrella organization over multiple Interoperability Forums**
 - **CAX-IF**
 - **EWIS-IF**
 - **PDM-IF**
 - **CAE-IF (*on hold*)**
- **Provides a common organization and infrastructure for the Interoperability Forums**

MBx-IF Project Framework

Global Product Data Interoperability Summit | 2023

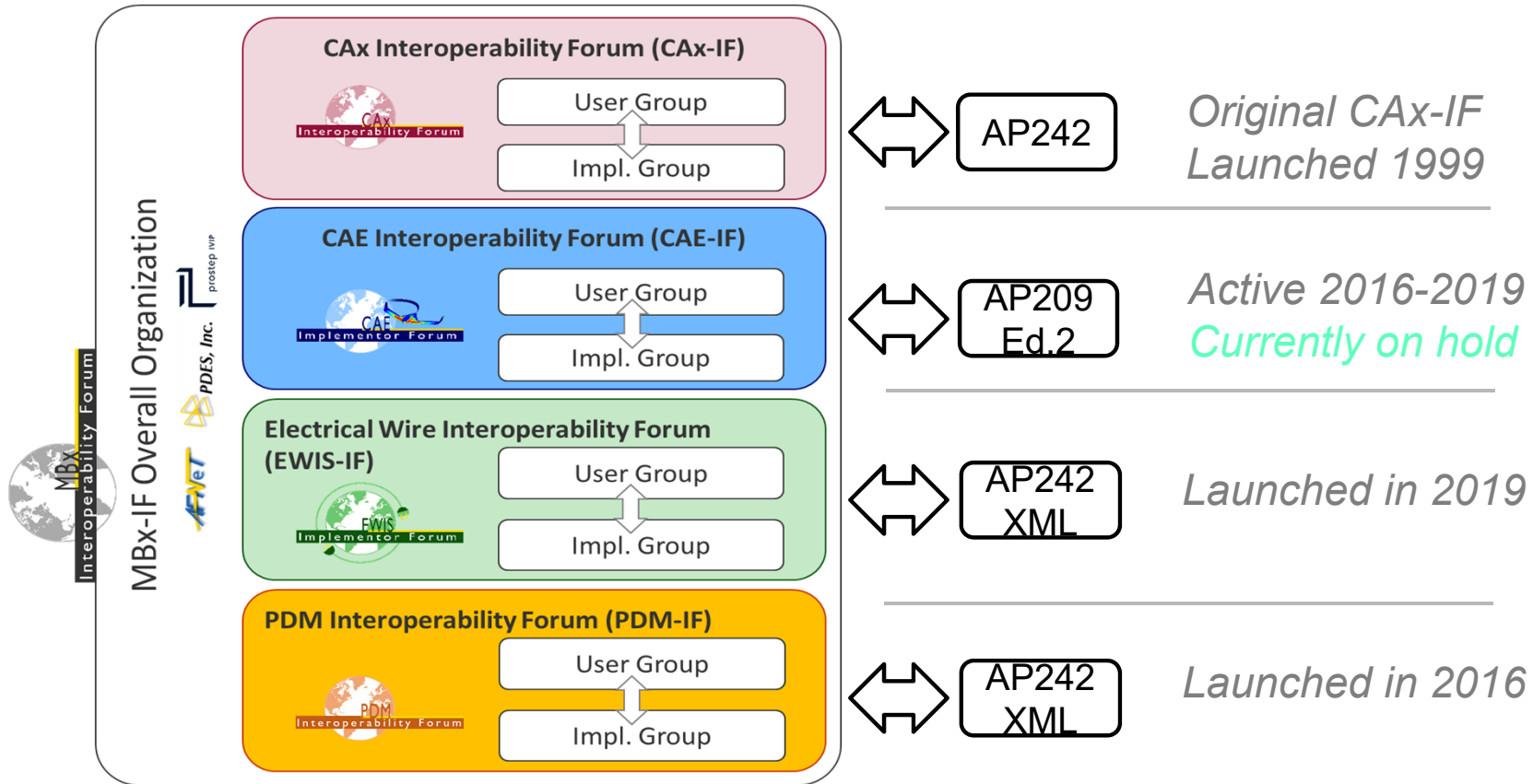

Visit the MBx-IF Homepage for more Information

Global Product Data Interoperability Summit | 2023

www.mbx-if.de / www.mbx-if.org / www.cax-if.eu

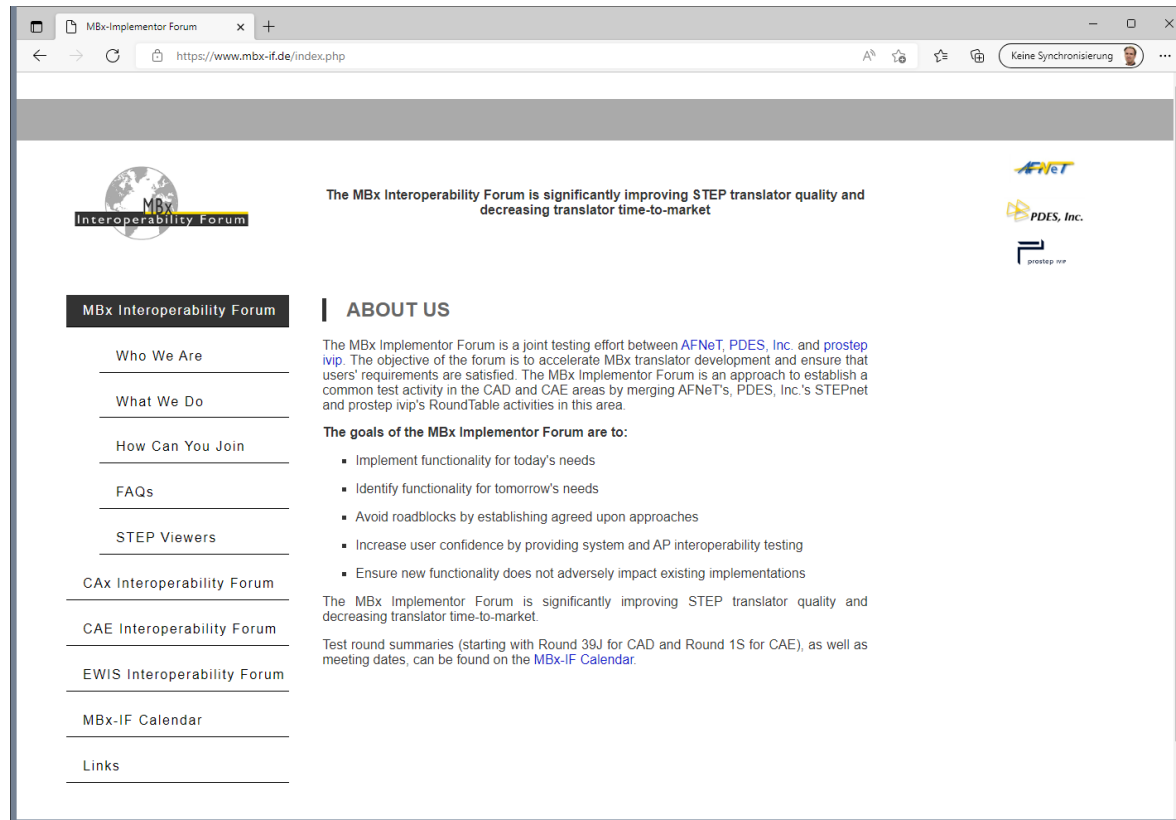

LOTAR WEBSITE

LOTAR Deliverables

LOTAR Homepage:

www.lotar-international.org

Global Product Data Interoperability Summit | 2023



LOTAR

LONG TERM ARCHIVING AND RETRIEVAL

Welcome to LOTAR International

LOTAR is an international consortium of Aerospace manufacturers, jointly facilitated by [AIA](#), [ASD-Stan](#), [AFNeT](#), [prostep ivip](#) and [PDES, Inc.](#)

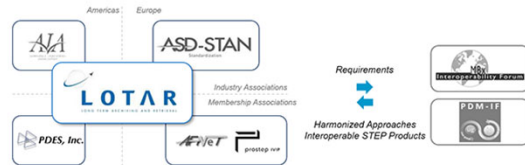

The prime objective is the creation and deployment of the **EN/NAS 9300 series of standards** for long-term archiving and retrieval of digital data, based on standardized approaches and solutions. The integration of LOTAR requirements into software tools is ensured by close cooperation with the [MBx Interoperability Forum](#) and the [PDM Implementor Forum](#).

LOTAR Organization

The development of a worldwide accepted standard for long term archiving of a 3D master and product structure is an international collaboration of five hosting organizations. The project is conducted in a distributed manner, using regular online meetings for management tasks as well as on the working group level, combined with physical team meetings alternating between Europe and the US for joint discussions.

[Learn more](#)

©2023 LOTAR International | [Contact](#) | [Imprint](#) | [Privacy](#)



Welcome

Why LOTAR?

- Introduction
- Mission, Objectives & Scope
- Legal & Business Motivation
- Technical & IT Background
- Goals & Benefits
- Joining LOTAR

LOTAR Organization

- External View
- Hosting Organizations
- Internal View
- Project Leadership Team
- Working together
- Fundamentals & Processes
- Member Companies

LOTAR Workgroups

- Basic & Common Parts
- Metadata for Archival Package
- 3D Mechanical CAD & PMI
- PDM
- Composites
- Electrical Harness
- Model-Based Systems Engineering
- Engineering Analysis & Simulation
 - Scope & Activities
 - Planning & Accomplishments
 - Documents
- 3D Visualization

Dates & Communication

- Public Presentations
- Progress Reports
- Next Steps

LOTAR Standard

- Overview on Parts
- Related Documents
- Industry Use

[News](#)

[Links](#)

NEXT STEPS

Work areas and upcoming events

Summary – Next Actions

Global Product Data Interoperability Summit | 2023

- **Leverage industry initiatives around digital engineering / digital thread**
- **Build on MBSE momentum**
- **Restart Engineering Analysis and Simulation**
- **Consider new domains such as software and circuit design**
- **Build on integration with Implementor Forums**
- **Activities planned**
 - **2023 Q3 Joint LOTAR workshop with GPDIS**
 - **2023 Q4 meeting online**
 - **2024 Q1 meeting in person – Darmstadt, DE, at prostep ivip**
 - **2024 Q2 meeting online**
 - **2024 Q3 LOTAR face to face in TBD, Americas**
 - **2024 Q4 meeting online**

Summary

Global Product Data Interoperability Summit | 2023

- **LOTAR is an industry consortium whose purpose is to develop process standards focused on the preservation of digital data required to be retained for long periods of time.**
- **Coordinate closely with implementor forums to develop test cases and recommended practices.**
- **Participants are primarily from the aerospace industry.**
- **Driven by business, regulatory, and customer requirements.**
- **Working groups meet regularly online.**
- **Gather for in depth quarterly meetings. Alternate in person and online meetings.**
- **Look forward to seeing you at our next meeting.**

- **If you are interested in participating, submit your information through the LOTAR website here <https://lotar-international.org/why-lotar/joining-lotar/>**

- **Thanks for joining us!**

- **Questions?**