

# Validating 3D Content in the Digital Thread

Tony Provencal  
*ITI, a Wipro Company*

# GLOBAL PRODUCT DATA INTEROPERABILITY SUMMIT 2023





The image shows a LinkedIn profile card for Tony Provencal. At the top left is a circular profile picture of a man with short dark hair, wearing a light blue shirt. To the right of the picture is the ITI logo, which consists of a red and blue diamond shape followed by the letters 'ITI' in a large, white, sans-serif font. Below the logo, it says 'a wipro company' in a smaller, white, sans-serif font. Further right, the text 'Experts in Product Data Interoperability' is written in a white, sans-serif font. In the top right corner of the profile card, there is a small white circle with a blue pencil icon. Below the profile picture, the name 'Tony Provencal' is written in a bold, black, sans-serif font. Underneath the name, it says 'Director of Technical Sales and Services at ITI' in a smaller, black, sans-serif font. Below that, it says 'Southborough, Massachusetts, United States · [Contact info](#)' in a smaller, black, sans-serif font. To the right of the name and title, there is a LinkedIn logo (a blue square with the letters 'in' in white) and a small white circle with a blue pencil icon. Below the LinkedIn logo, there are two company logos: the ITI logo followed by 'International Technegroup Inc.' and a small square logo followed by 'University of Notre Dame'.

**Tony Provencal**  
Director of Technical Sales and Services at ITI  
Southborough, Massachusetts, United States · [Contact info](#)

[International Technegroup Inc.](#)  
[University of Notre Dame](#)

[tony.provencal@iti-global.com](mailto:tony.provencal@iti-global.com)  
[www.linkedin.com/in/tonyprovencal](https://www.linkedin.com/in/tonyprovencal)  
+1 (617)306-5676

# About ITI: 40 Years of CAD and PLM Interoperability Expertise

Global Product Data Interoperability Summit | 2023

## Software Development Partnerships



## Product Data Standards



## Industry Associations



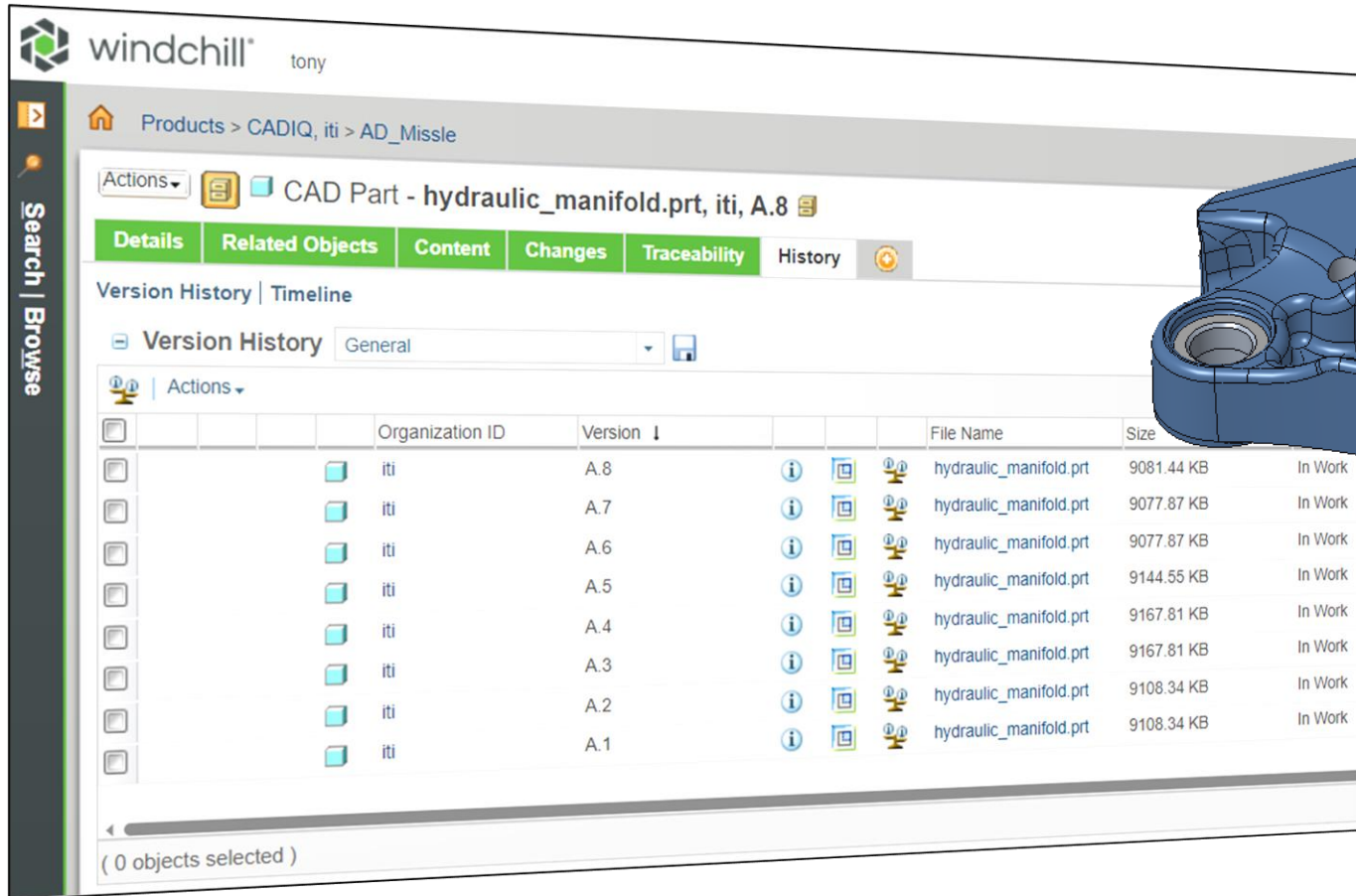

# 3D Content in the Digital Thread

Global Product Data Interoperability Summit | 2023





windchill® tony

Products > CADIQ, iti > AD\_Missle



































Actions ▾  CAD Part - hydraulic\_manifold.prt, iti, A.8 

Details Related Objects Content Changes Traceability History 

Version History | Timeline

 Version History  

 Actions ▾

| <input type="checkbox"/> | <input type="checkbox"/> | <input type="checkbox"/>  | Organization ID | Version ↓ |    |    |    | File Name              | Size       |         |
|--------------------------|--------------------------|---|-----------------|-----------|---|---|---|------------------------|------------|---------|
| <input type="checkbox"/> | <input type="checkbox"/> |    | iti             | A.8       |    |    |    | hydraulic_manifold.prt | 9081.44 KB | In Work |
| <input type="checkbox"/> | <input type="checkbox"/> |    | iti             | A.7       |    |    |    | hydraulic_manifold.prt | 9077.87 KB | In Work |
| <input type="checkbox"/> | <input type="checkbox"/> |    | iti             | A.6       |    |    |    | hydraulic_manifold.prt | 9077.87 KB | In Work |
| <input type="checkbox"/> | <input type="checkbox"/> |    | iti             | A.5       |    |    |    | hydraulic_manifold.prt | 9144.55 KB | In Work |
| <input type="checkbox"/> | <input type="checkbox"/> |  | iti             | A.4       |  |  |  | hydraulic_manifold.prt | 9167.81 KB | In Work |
| <input type="checkbox"/> | <input type="checkbox"/> |  | iti             | A.3       |  |  |  | hydraulic_manifold.prt | 9167.81 KB | In Work |
| <input type="checkbox"/> | <input type="checkbox"/> |  | iti             | A.2       |  |  |  | hydraulic_manifold.prt | 9108.34 KB | In Work |
| <input type="checkbox"/> | <input type="checkbox"/> |  | iti             | A.1       |  |  |  | hydraulic_manifold.prt | 9108.34 KB | In Work |

( 0 objects selected )

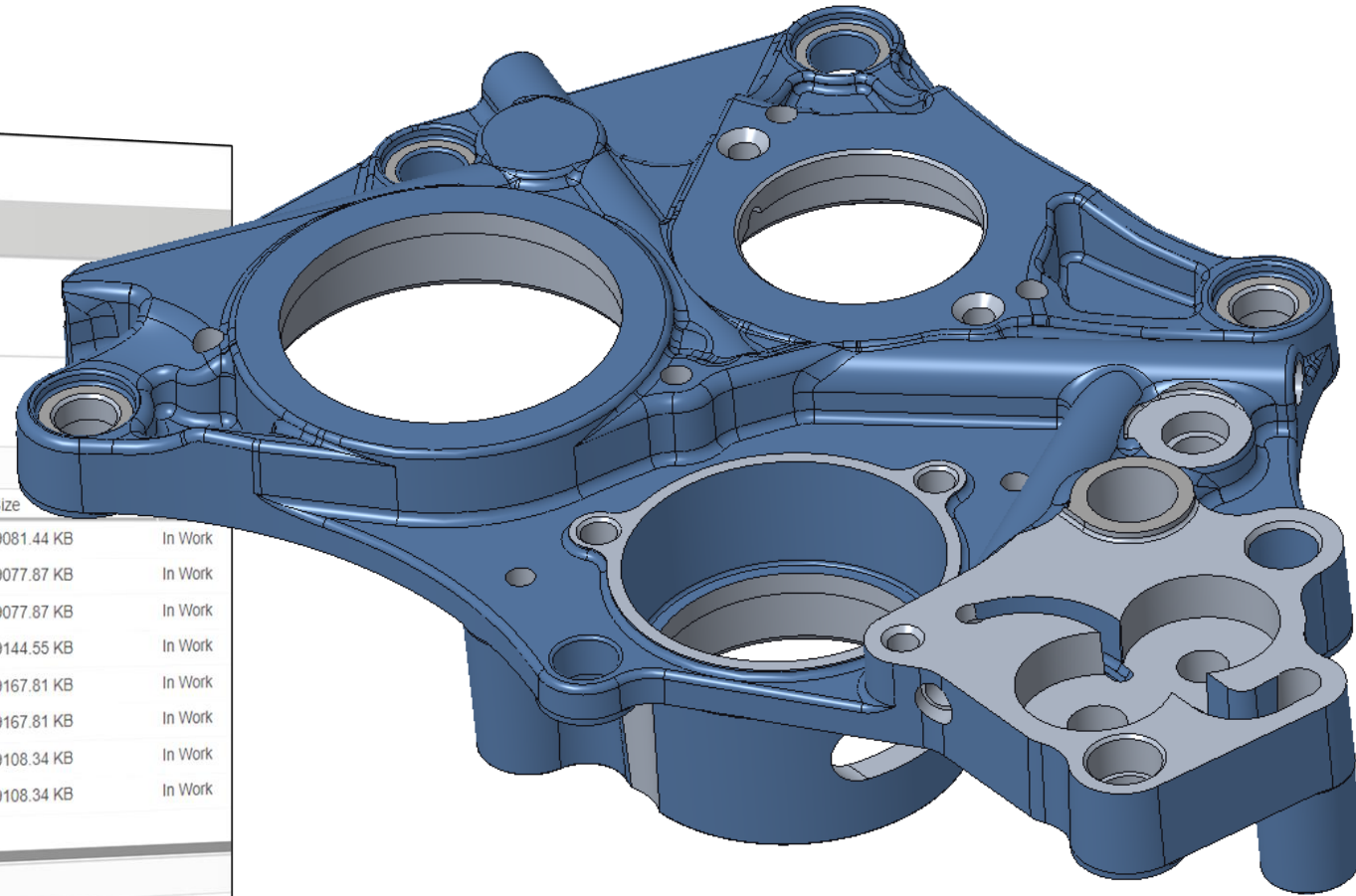

# Today's Topics – How are Companies Approaching Validation of 3D Content?

Global Product Data Interoperability Summit | 2023

windchill® tony

Products > CADIQ, iti > AD\_Missile

Actions CAD Part - hydraulic\_manifold.prt, iti, A.8

Details Related Objects Content Changes Traceability History

Version History | Timeline

Version History General

| Organization ID | Version | File Name              | Size       | State   |
|-----------------|---------|------------------------|------------|---------|
| iti             | A.8     | hydraulic_manifold.prt | 9081.44 KB | In Work |
| iti             | A.7     | hydraulic_manifold.prt | 9077.87 KB | In Work |
| iti             | A.6     | hydraulic_manifold.prt | 9077.87 KB | In Work |
| iti             | A.5     | hydraulic_manifold.prt | 9144.55 KB | In Work |
| iti             | A.4     | hydraulic_manifold.prt | 9144.55 KB | In Work |
| iti             | A.3     | hydraulic_manifold.prt | 9144.55 KB | In Work |
| iti             | A.2     | hydraulic_manifold.prt | 9144.55 KB | In Work |
| iti             | A.1     | hydraulic_manifold.prt | 9108.34 KB | In Work |

(0 objects selected)

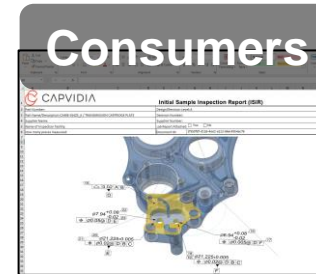
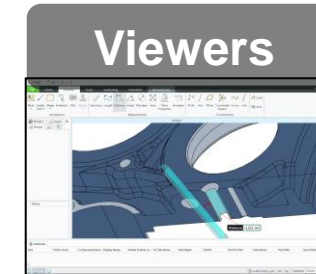
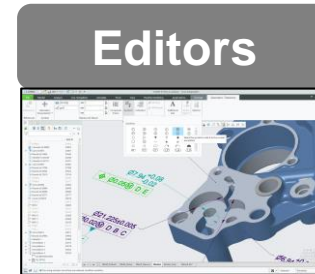

- **Modeling Practices Impact**
- **Common Standards & Formats**
- **Manual vs. Programmatic**
- **Pass/Fail Gates vs. Information Report**
- **Data Author vs. Data Receiver**

# Modeling Practices Impact Data Publishing and Re-use

Global Product Data Interoperability Summit | 2023

- **2D Drafting Practices in 3D**
- **Use of Specialized Modules**
  - Sheetmetal
  - Piping/Tubing
  - Weldments
  - Composites
- **Use of Alternate Displays**
  - Reference Sets/Simplified Reps/Configurations
  - Internal Manufacturing Models
  - Security Marking Handling
- **Assembly Features**
- **Flexible Components**
- **PMI Graphics Handling**
- **PMI Geometry References**

# Standards & Common Use Cases

Global Product Data Interoperability Summit | 2023

|   | <b>STEP</b>                    | <b>JT</b>                            | <b>QIF</b>              | <b>PDF (PRC)</b>                                  | <b>WebGL/gLTF</b>                    | <b>STL</b>                            | <b>3MF</b>     |
|---|--------------------------------|--------------------------------------|-------------------------|---|--------------------------------------|---------------------------------------|----------------|
| <b>Standard</b>                           | ISO 10303                      | ISO 14306                            | ISO 23952               | ISO 14739   | ISO 12113                            | n/a                                   | ISO 52915      |
| <b>Technical Committee/<br/>Consortia</b> | PDES/PROSTEP                   | JT Open                              | DMSC                    | 3D PDF Consortium<br>ISO/TC 171/SC 2              | ISO/IEC JTC 1                        | n/a                                   | 3MF Consortium |
| <b>Precise Geometry</b>                   | Yes                            | Yes                                  | Yes                     | No*   | Yes                                  | No                                    | No             |
| <b>Tessellated Geometry</b>               | No*                            | Yes                                  | No                      | Yes   | Yes                                  | Unstructured<br>triangulated surfaces | Polygon mesh   |
| <b>Attributes</b>                         | Yes                            | Yes                                  | Yes                     | Yes   | Yes                                  | No                                    | Yes            |
| <b>Saved Views</b>                        | Yes                            | Yes                                  | Yes                     | Yes   | Yes                                  | No                                    | No             |
| <b>Graphical PMI</b>                      | Yes                            | Yes                                  | No                      | Yes   | Yes                                  | No                                    | No             |
| <b>Semantic PMI</b>                       | Yes                            | Yes                                  | Yes                     | No  | No                                   | No                                    | No             |
| <b>Enhanced Data</b>                      | GVP, CoP, PMI<br>ValProps      | JT+ PDF                              | PMI Optimization        | Notes, BOM, External<br>Data Sources              | Notes, BOM, External<br>Data Sources |                                       |                |
| <b>Common Use Cases</b>                   | Geometry<br>Translation, LOTAR | Visualization,<br>Translation, LOTAR | FAI, CMM<br>Programming | Collaboration/Visualiza<br>tion/Work Instructions | Collaboration/Visualiza<br>tion      | 3D Printing                           | 3D Printing    |

# Manual vs Programmatic Validation

Global Product Data Interoperability Summit | 2023

- 3D model driven data requires automation because of presentation and behavior characteristics
- For derivative formats, consistency between graphical copies (human interpretation) and semantic copies (machine interpretation) is critical
- Two critical paths for enabling trust in the digital
  - Identify and correct issues everywhere reasonable
  - Override processes should document uncorrectable issues

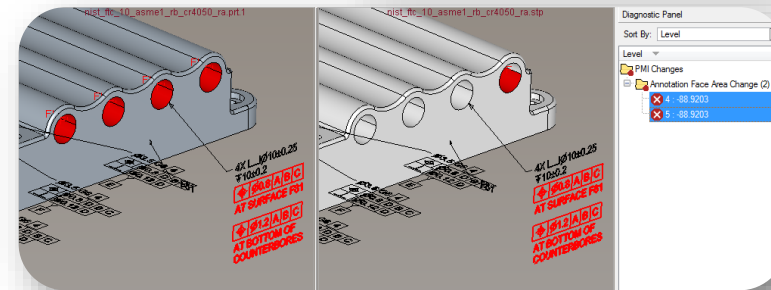
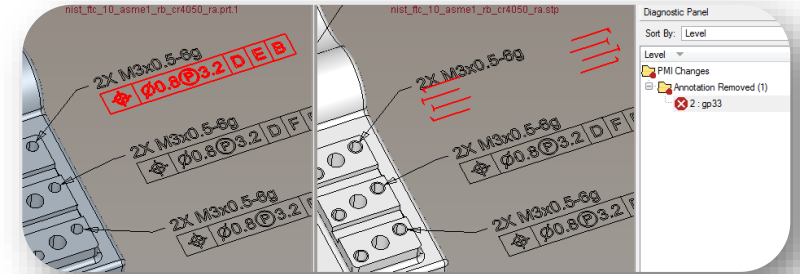
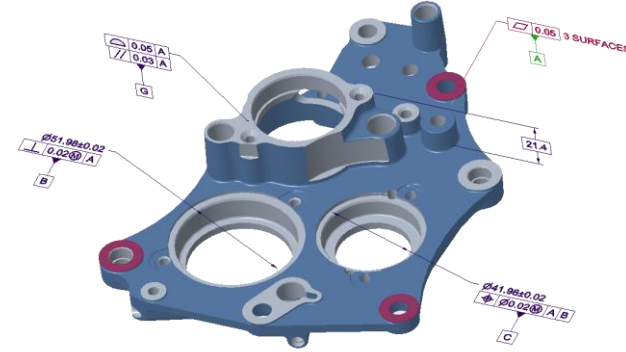



**Validation is Process Dependent**



**Validation is Time Dependent**



**Validation is Consumption Dependent**



# Simplified MILSTD 31000 Data Delivery Scenario – Author/Design Authority

Global Product Data Interoperability Summit | 2023

## DESIGN ACTIVITIES

## STAGING & PUBLISHING

## PACKAGING

### CAD BOM

| Model Tree                         |    |
|------------------------------------|----|
| 13G-4300.ASM                       |    |
| ASM_RIGHT                          | 1  |
| ASM_TOP                            | 3  |
| ASM_FRONT                          | 5  |
| ASM_DEF_CSYS                       | 7  |
| ▶ 21G-1224A.PRT                    | 39 |
| ▶ 12G-2402.PRT                     | 42 |
| ▶ Pattern 1 of K0721_CAP_SCREW.PRT | 46 |
| SHAFT_LOCK_PLANE0                  | 51 |
| ▶ 12G-7723A.PRT                    | 50 |
| LOCK_PLANE_240                     | 55 |
| LOCK_PLANE_120                     | 57 |
| ▶ 12G-7723A.PRT                    | 59 |
| ▶ 12G-7723A.PRT                    | 62 |

### CAD Dataset

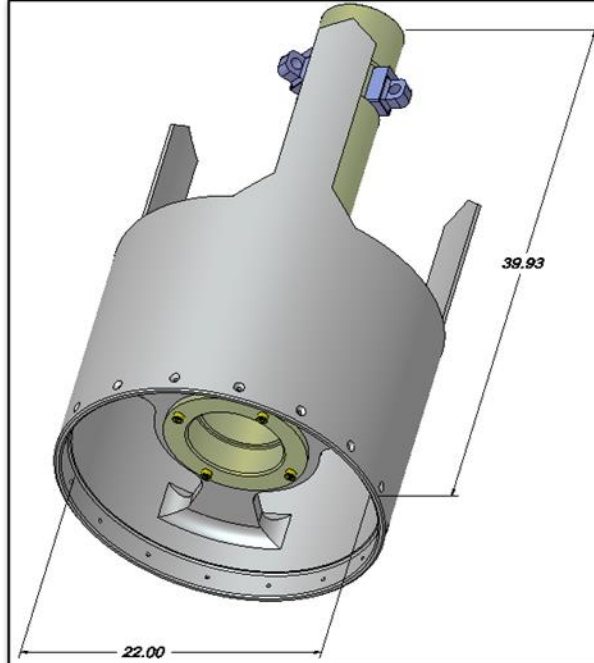

### On Disk

| Name                  |
|-----------------------|
| 12g-2402.prt.1        |
| 12g-7723a.prt.1       |
| 13g-4300.asm.1        |
| 21g-1224a.prt.1       |
| k0721_cap_screw.prt.1 |

### Data Package\*

| Name                    |
|-------------------------|
| 12g-2402.pdf            |
| 12g-2402.prt.1          |
| 12g-2402_prt.stp        |
| 12g-7723a.pdf           |
| 12g-7723a.prt.1         |
| 12g-7723a_prt.stp       |
| 13g-4300.asm.1          |
| 13g-4300.pdf            |
| 13g-4300_asm.stp        |
| 21g-1224a.pdf           |
| 21g-1224a.prt.1         |
| 21g-1224a_prt.stp       |
| k0721_cap_screw.pdf     |
| k0721_cap_screw.prt.1   |
| k0721_cap_screw_prt.stp |

# Simplified MILSTD 31000 Data Delivery Scenario – Author/Design Authority Validation

Global Product Data Interoperability Summit | 2023

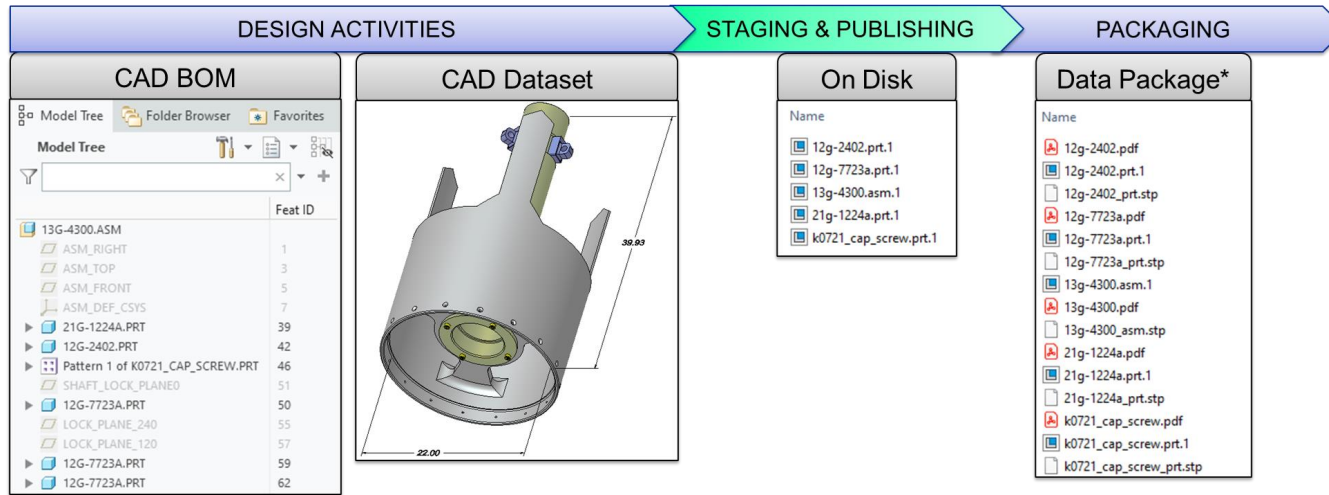

## Staging & Publishing Validation

- Are there known publishing issues the with CAD models?
- Are they missing any required security markings?
- Are any of the markings empty or filled out incorrectly?
- For “Type 3D”, is all content (STEP/3Di PDF) accurate and complete?

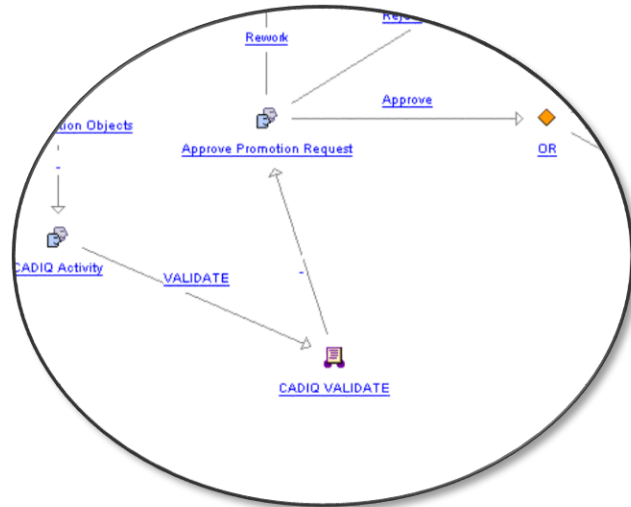

# Simplified MILSTD 31000 Data Delivery Scenario – Data Owner/Receiver Validation

Global Product Data Interoperability Summit | 2023

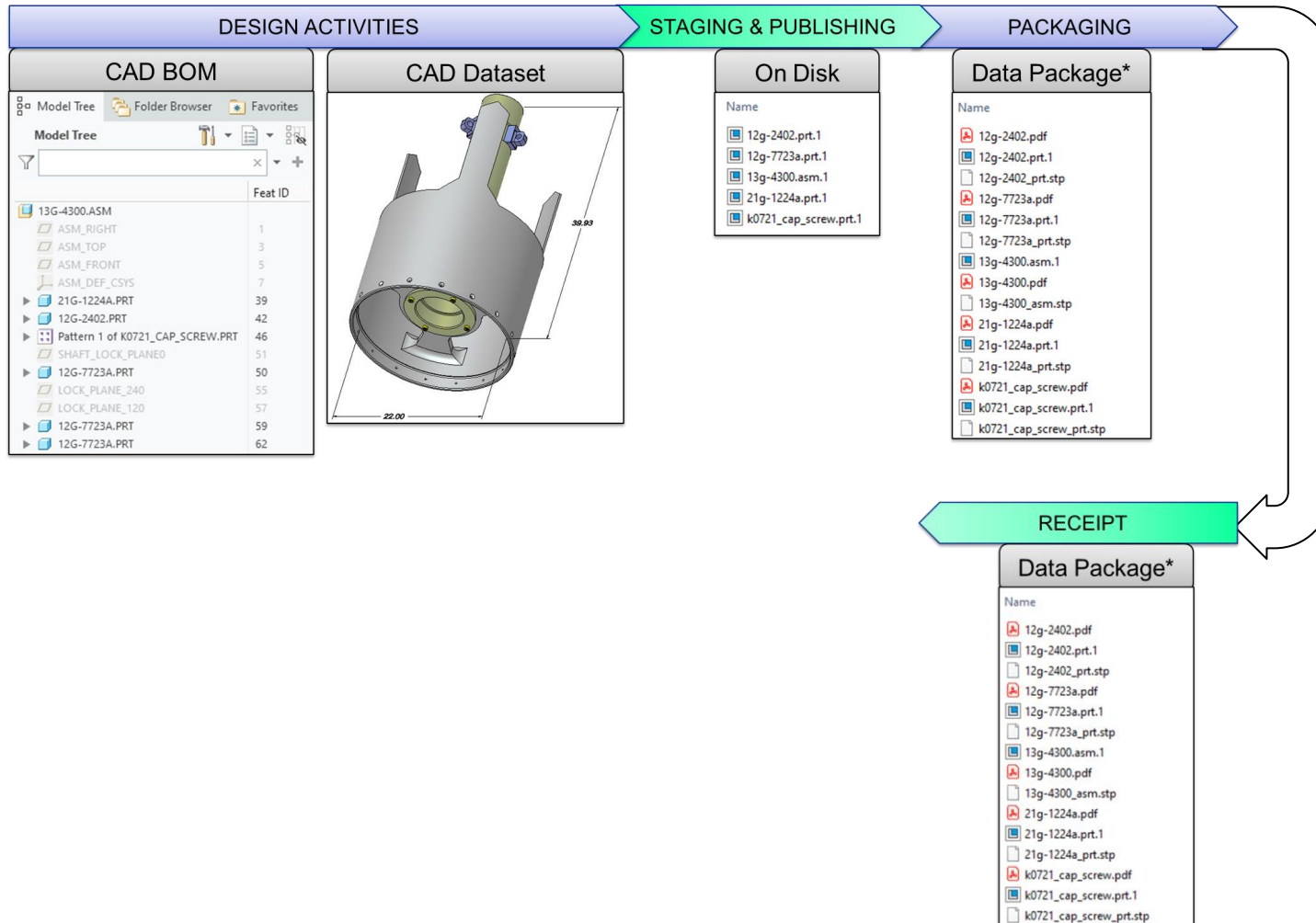

## Data Receipt Validation

- Did package include all the BOM models?
- Is all the metadata correct?
- For “Type 3D”, are all files included and accurate (STEP/3Di PDF)?

# Tips for Digital Validation

Global Product Data Interoperability Summit | 2023

- Review the standard 3D elements in your Digital Thread
  - Automated content
  - Manual content
- Use production data to evaluate publishing and validation options
- Collect data for SME evaluation as well as user feedback
- Automate workflow elements based on variability of processes
  - Geometry + Graphic PMI (JT/PDF)= Low
  - Geometry + Semantic PMI = High
- Only build gates for critical items
- Leverage the Industry

**QIF Validation Report**

Job Information: Date of Analysis: Fri Aug 18 13:42:23 2023, CADIQ Version: 16.1.1, Build Date: July 14, 2023

Summary: **PASS**

| Saved View    | Geometry | PMI | Attribute |
|---------------|----------|-----|-----------|
| CADIQ Default | ●        | ●   | ●         |
| D3_PROPERTIES | ●        | ●   | ●         |
| D5_DATUMS     | ●        | ●   | ●         |
| D7R_TOP       | ●        | ●   | ●         |
| D8A_SECTION_A | ●        | ●   | ●         |
| D8B_SECTION_B | ●        | ●   | ●         |
| DEFAULT ALL   | ●        | ●   | ●         |

Model Information: mbd\_hydraulic\_manifold\_updated.prt, Part Number: MBD\_HYDRAULIC\_MANIFOLD\_UPDATED.qif, Creo Parametric 6.0, Model Format: QIF

Visualization and Attributes | More Attributes

Visualization and Attributes

File Name: cx408-01429rgh.prt  
Number: CX408-01429RGH.PRT  
Name: cx408-01429rgh.prt  
Status: Checked in  
Modified By: Tony

**CADIQ**

CADIQ\_Template\_Parameter: Standard\_Precision\_mm  
CADIQ\_CHECK\_Result: FAIL  
CADIQ\_VALIDATE\_Result: IGES\_CX408-01429RGH=FAIL, STEP\_CX408-01429RGH=FAIL